



Ningbo Haitian Precision Machinery Co., Ltd.

H.Q. & Production Base1

No. 1688 Haitian road, Xiaogang, Beilun, Ningbo-315801, China.
Tel: +86-574-86182580/86182525
E-mail: hision@mail.haitian.com

Production Base2

No.235, Huangshan Road, Beilun District, Ningbo-315801 China.

Production Base3

No.188, Baodao Road, Lingang Industrial Zone, Changxing Island, Dalian-116317 China.

Haitian Precision Machinery (HONGKONG) Co., Ltd.

Office Address:

Unit, 12/F, Seabright Plaza, 9-23 Shell Street, North Point, HONGKONG.

Website:

www.haitianprecision.com

HORIZONTAL MACHINING CENTER

H63 II / H80 II / H100 II / H125 II / H160 II



PRODUCT INTRODUCTION

The machine adopts advanced T type bed structure, gantry type column, positive hanging box layout, strong rigidity and high precision retention, which is suitable for the rough and finishing requirements of precision level box parts.

Products are widely used in automotive, rail transit, valves, mining machinery, textile machinery, plastic machinery, ships, electricity and other areas.

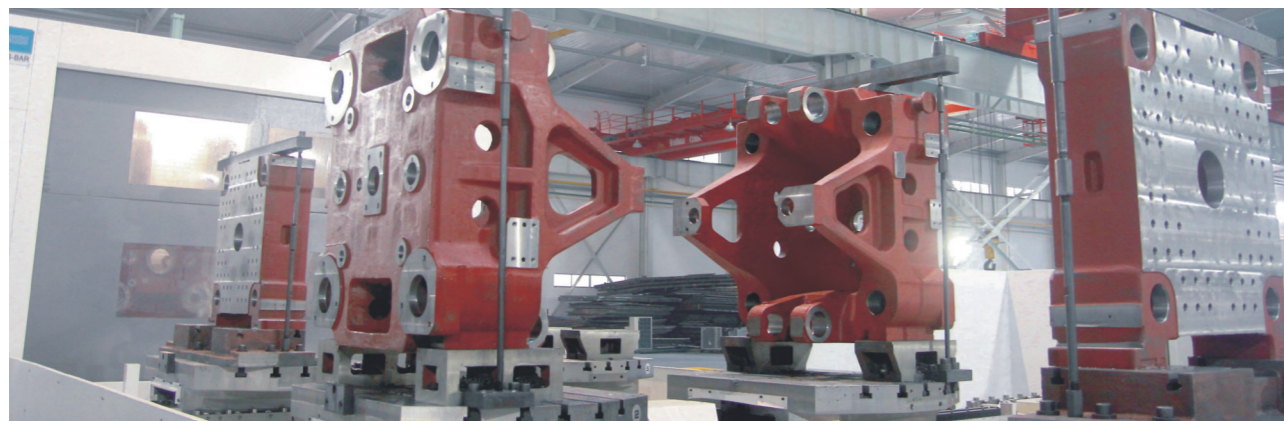

HORIZONTAL MACHINING CENTER

H63II-H125 II [Page 05]



H100II/D [Page 06]

H125II/D [Page 06]



H160II [Page 07]

H160II/D [Page 07]





HII-HII/D

The machine adopts advanced T type bed structure, gantry type column, positive hanging box layout, strong rigidity and high precision retention, which is suitable for the rough and finishing requirements of precision level box parts.

Products are widely used in automotive, rail transit, valves, mining machinery, textile machinery, plastic machinery, ships, electricity and other areas.

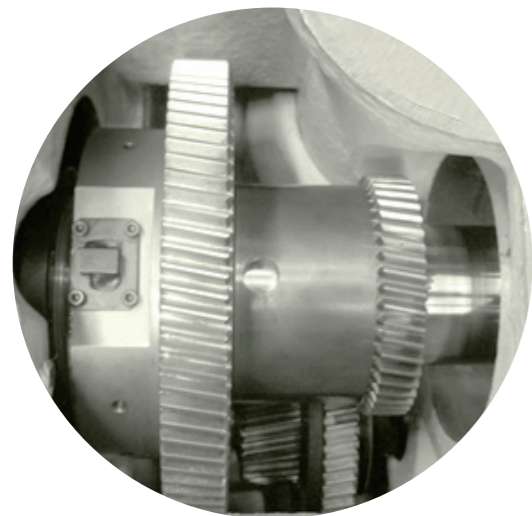

Strong Main Drive

The spindle box adopts two-stage gear speed change to ensure high torque output at low speed. The spindle bearing adopts the combination of angular contact bearing and double row cylindrical roller bearing to meet the requirements of heavy cutting.

W Axis Function

It has a W axis function with a stroke of 535mm and a diameter of 130mm, guided by a high-precision linear guide rail, and driven directly by a ball screw and a servo motor.

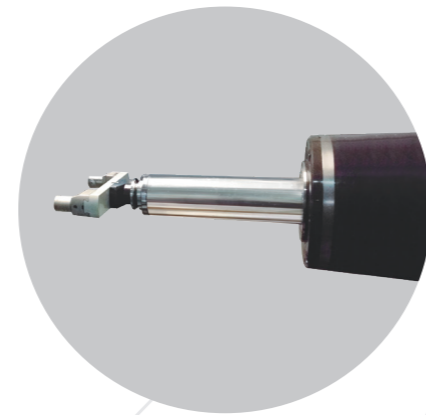

HII-HII/D



Y-Axis Guide Rail Structure

After quenching and grinding, the guide rail has large section size and good rigidity. The symmetry of thermal deformation in all directions is ensured through seven contact surfaces.

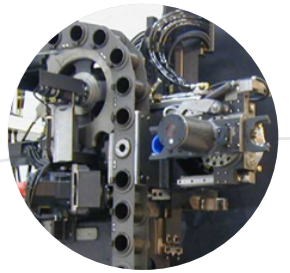

Arm Type Tool Magazine

HISON tool magazine, arm imported from Japan, with stable and reliable performance.

CNC Turntable With Patented Technology

The patented CNC turntable adopts special YRT turntable bearings, with three rows of rollers for axial and radial support. The clamping torque of the table is large, and the anti overturning torque is strong.

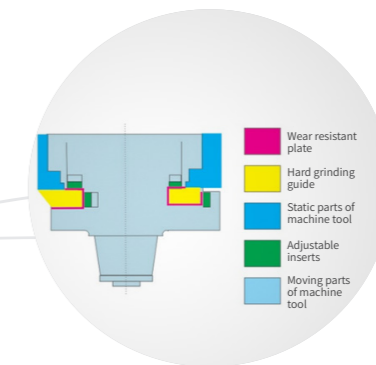



HII

Items	Unit	H63 II	H80 II	H100 II	H125 II
» Machining Capacity					
X travel	mm	1050	1350	1800	2000
Y travel	mm	850	980	1500	1500
Z travel	mm	900	1000	1350	1350
W travel	mm	----	535(Option)	535(Option)	535(Option)
Spindle center to table surface	mm	0-850	0-980	0-1500	0-1500
Spindle nose to table center	mm	200-1100	230-1230	300-1650	350-1700
» Table					
Table size	mm	630×630	800×800	1000×1000	1250×1250
Table load	kg	1300	2000	3000	3000
Pallet indexing	°	1° ×360	1° ×360	1° ×360	1° ×360
Pallet change type		Rotary type	Rotary type	Rotary type	Rotary type
Pallet quantity		2	2	2	2
» Feed Rate					
Cutting feedrate (X/Y/Z)	m/min	12/12/12	12/12/12	6/6/6	6/6/6
Rapid traverse (X/Y/Z)	m/min	32/30/32	30/24/30	24/20/24	24/20/24
» Spindle					
Spindle speed	rpm	6000	6000	4500	4500
Spindle power	kW	18.5/22	18.5/22	22/26	22/26
Spindle torque	N.m	703/837	703/837	837/989	837/989
Spindle taper		BT50	BT50	BT50	BT50
Boring bar diameter	mm	----	Φ130(Option)	Φ130(Option)	Φ130(Option)
» Tool Magazine					
Pull stud		P50T-2-MAS403	P50T-2-MAS403	P50T-2-MAS403	P50T-2-MAS403
Tool magazine capacity	T	40	40	40	40
Max.tool dia. (Adjacent/vacant)	mm	Φ120 / Φ240	Φ120 / Φ240	Φ120 / Φ240	Φ120 / Φ240
Max.tool length	mm	550	550	650	650
Max.tool weight	kg	30	30	30	30
» Accuracy					
Positioning accuracy(X/Y/Z)	mm	0.012 (0.008 with linear scale)	0.012 (0.01 with linear scale)	0.015 (0.012 with linear scale)	0.015 (0.012 with linear scale)
Repeatability(X/Y/Z)	mm	0.006 (0.005 with linear scale)	0.008 (0.006 with linear scale)	0.010 (0.008 with linear scale)	0.010 (0.008 with linear scale)
» Other					
Power capacity	kVA	45	45	55	55
Machine weight	t	17	22	32	33
Machine size(L×W×H)	mm	6750×4650×3800	7530×5000×4300	9000×5200×4600	9000×5200×4600

Standard Configuration

1. Contoller: FANUC 0i
2. Gear box drive
3. 1° index pallet
4. 40T ATC
5. APC (Auto pallets changer)
6. Pneumatic,hydraulic and lubrication system
7. Spindle oil chiller
8. Cutting cooling
9. Internal helix chip conveyor
10. 3-color signal lamp, working light
11. Full enclosure with top cover
12. Standard accessories
13. Common maintenance tools
14. External chain type chip conveyor

Option Configuration

1. Contoller: SIEMENS
2. 0.001° index pallet
3. T slot table enlarge
4. CTS (2/3-6MPa)
5. 60/90/120T tool magazine
6. Screw hole table (H63II/H80II)
7. W axis function (Φ130mm, except H63II)
8. AC for electrical cabinet (H63II/H80II)
9. Linear scale
10. Workpiece probe
11. Tool setter
12. Oil skimmer
13. Air gun
14. Water gun

HII/D

Items	Unit	H100 II/D	H125 II/D
» Machining Capacity			
X travel	mm	1800	2000
Y travel	mm	1500	1500
Z travel	mm	1350	1350
W travel	mm	535(Option)	535(Option)
Spindle center to table surface	mm	100-1600	100-1600
Spindle nose to table center	mm	300-1650	350-1700
» Table			
Table size	mm	1000×1000	1250×1250
Table load	kg	3000	3000
Pallet indexing	°	1° ×360	1° ×360
Pallet change type		----	----
Pallet quantity		----	----
» Feed Rate			
Cutting feedrate (X/Y/Z)	m/min	6/6/6	6/6/6
Rapid traverse (X/Y/Z)	m/min	24/20/24	24/20/24
» Spindle			
Spindle speed	rpm	4500	4500
Spindle power	kW	22/26	22/26
Spindle torque	N.m	837/989	837/989
Spindle taper		BT50	BT50
Boring bar diameter	mm	Φ130(Option)	Φ130(Option)
» Tool Magazine			
Pull stud		P50T-2-MAS403	P50T-2-MAS403
Tool magazine capacity	T	40	40
Max.tool dia. (Adjacent/vacant)	mm	Φ120 / Φ240	Φ120 / Φ240
Max.tool length	mm	650	650
Max.tool weight	kg	30	30
» Accuracy			
Positioning accuracy(X/Y/Z)	mm	0.015 (0.012 with linear scale)	0.015(0.012 with linear scale)
Repeatability(X/Y/Z)	mm	0.010(0.008 with linear scale)	0.010(0.008 with linear scale)
» Other			
Power capacity	kVA	55	55
Machine weight	t	30.5	31.5
Machine size(L×W×H)	mm	6130×5200×4600	6130×5200×4600

Standard Configuration

1. Contoller: FANUC 0i
2. Gear box drive
3. 1° index pallet
4. 40T ATC
5. Pneumatic,hydraulic and lubrication system
6. Spindle oil chiller
7. Cutting cooling
8. Internal helix chip conveyor
9. 3-color signal lamp, working light
10. Full enclosure with top cover
11. Standard accessories
12. Common maintenance tools
13. External chain type chip conveyor

Option Configuration

1. Contoller: SIEMENS
2. 0.001° index pallet
3. T slot table enlarge
4. CTS (2/3-6MPa)
5. 60/90/120T arm tool magazine
6. Y travel 1700mm
7. W axis function (Φ130mm)
8. Linear scale
9. Workpiece probe
10. Tool setter
11. Oil skimmer
12. Air gun
13. Water gun



HI/D

Items	Unit	H160II	H160II/D
» Machining Capacity			
X travel	mm	2500	2500
Y travel	mm	1850	2000
Z travel	mm	1500	1500
W travel	mm	700	700
Spindle center to table surface	mm	0-1850	120-2120
Spindle nose to table center	mm	580-2080	580-2080
» Table			
Table size	mm	1600×1800	1600×1800
Table load	kg	8000	10000
Pallet indexing	°	0.001	0.001
Pallet change type		Parallel type	----
Pallet quantity		2	----
» Feed Rate			
Cutting feedrate (X/Y/Z)	m/min	6/6/6	6/6/6
Rapid traverse (X/Y/Z)	m/min	10/10/10	10/10/10
» Spindle			
Spindle speed	rpm	2500	2500
Spindle power	kW	30/37	30/37
Spindle torque	N.m	1846/2277	1846/2277
Spindle taper		BT50	BT50
Boring bar diameter	mm	Φ130	Φ130
» Tool Magazine			
Pull stud		P50T-2-MAS403	P50T-2-MAS403
Tool magazine capacity	T	40	40(Option)
Max.tool dia. (Adjacent vacant)	mm	Φ120 / Φ240	Φ120 / Φ240
Max.tool length	mm	650	650
Max.tool weight	kg	30	30
» Accuracy			
Positioning accuracy (X/Y/Z)	mm	0.020 (0.015 with linear scale)	0.020 (0.015 with linear scale)
Repeatability (X/Y/Z)	mm	0.012 (0.010 with linear scale)	0.012 (0.010 with linear scale)
» Other			
Power capacity	kVA	84	64
Machine weight	t	55	46
Machine size (L×W×H)	mm	13200×7300×6000	8030×7300×6000

Standard Configuration

1. Controller: FANUC 0i
2. Gear box drive
3. NC table index 0.001°
4. 40T ATC (H160II/D option)
5. Pneumatic,hydraulic and lubrication system
6. Spindle oil chiller
7. Cutting cooling
8. Internal helix chip conveyor
9. 3-color signal lamp, working light
10. Full enclosure with top cover (H160II/D option)
11. Standard accessories
12. Common maintenance tools
13. External chain type chip conveyor

Option Configuration

1. Controller: SIEMENS
2. Axis travel increase
3. T slot table enlarge
4. CTS (2/3-6MPa)
5. 60/90/120T arm tool magazine
6. W axis function (Φ130mm)
7. Linear scale
8. Workpiece probe
9. Tool setter
10. Oil skimmer
11. Air gun
12. Water gun

Worktable Size And Workpiece Clamping Range

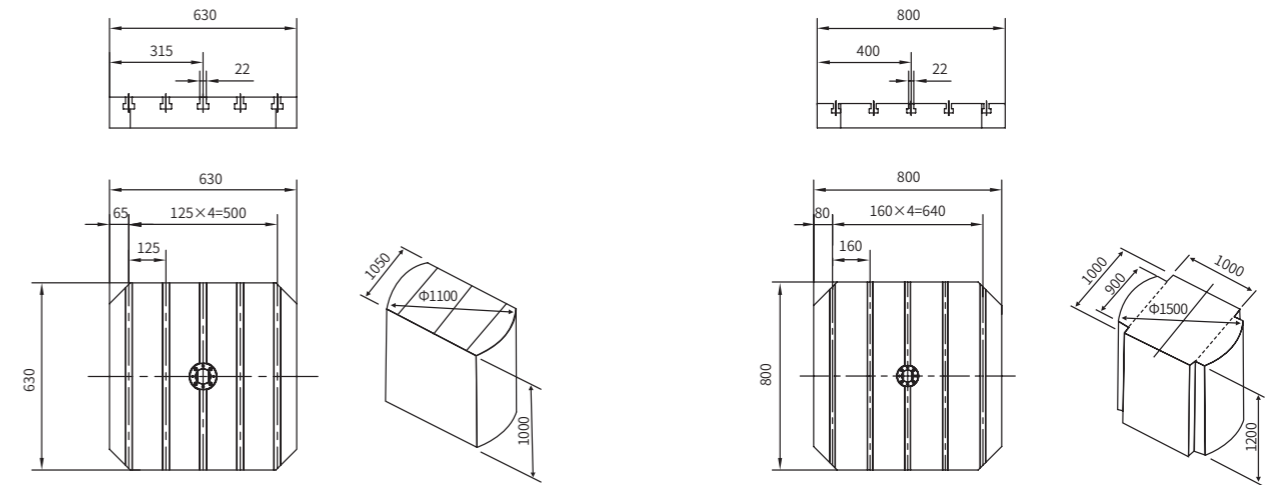

H63II Worktable size

H80II Worktable size

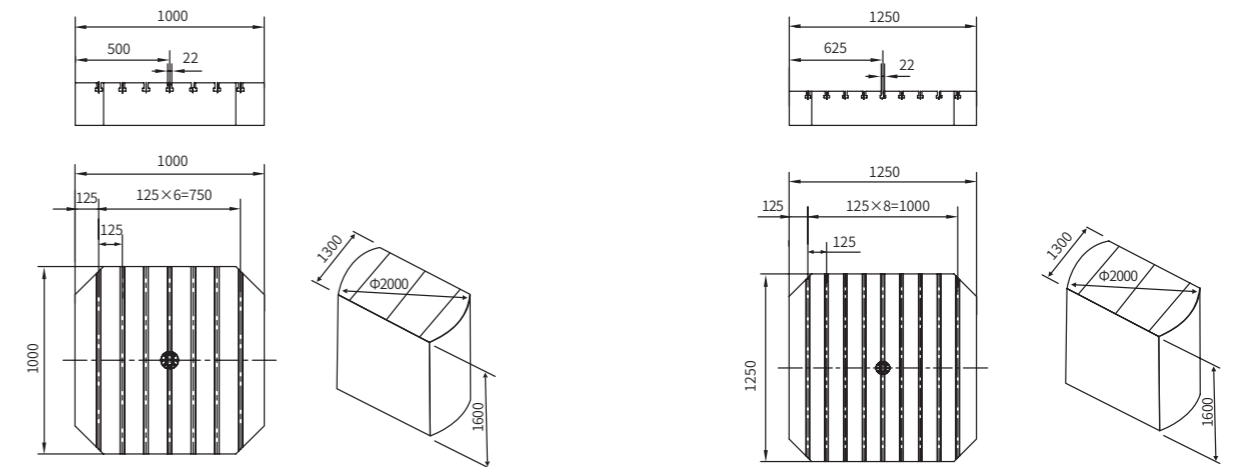

H100II Worktable size

H125II Worktable size

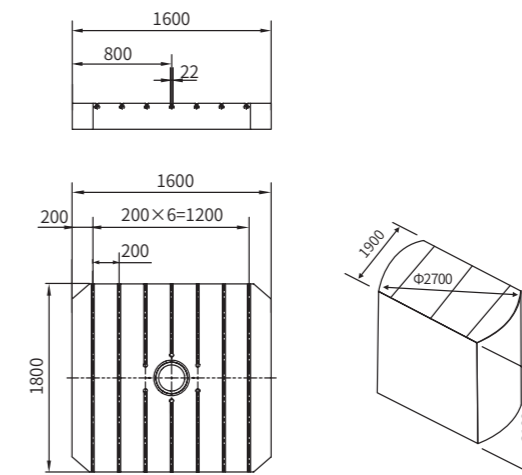

H160II Worktable size



- Manufacturing Base
- Overseas Subsidiary
- Overseas Market



MORE THAN PRECISION

Ningbo Haitian Precision Machinery Co., Ltd. is a listed company specializing in machine tooling industry. It has developed Ningbo Dagang production base, Ningbo Yanshan production base and Dalian production base. It has a modern constant temperature processing and assembly plant of over 300,000 square meters with nearly 1900 employees. It is awarded honors such as “national major technical equipment enterprise”, “national high-tech enterprise”, and “provincial high-tech research and development center”.

