



"Large Flow" Water Heater

STM-607WF



Refer carefully to this manual before operation.

STM-WF Series

■ Coding Principle

STM - xxxx WF

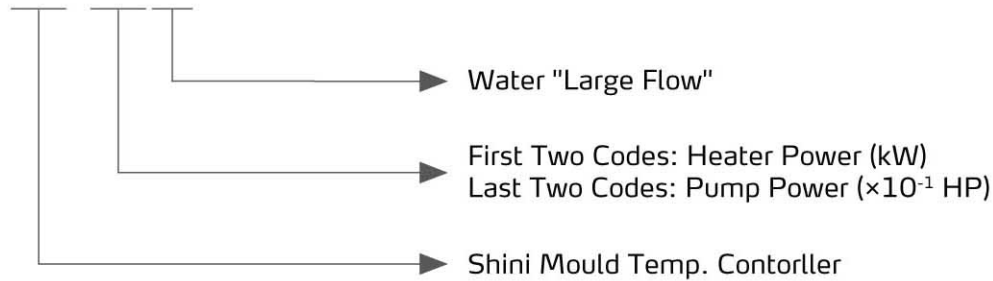

■ Features

Standard configuration

- Controller adopts 3.2 " LCD for easy operation.
- Equipped with the design of 7-day automatic start/stop timer. LCD screen can be converted between Chinese and English. The unit of temperature can be converted between °F and °C.
- P.I.D. multi-stage temperature control system can maintain a mould temperature with an accuracy of $\pm 0.5^{\circ}\text{C}$.
- Multiple safety devices including power reverse phase protection, pump overload protection, overheat protection and low level protection that can automatically detect abnormal performance and indicate this via visible alarm.
- Adopts large-flow pump with high stable performance, which especially suitable for extrusion molding and applications alike.
- Direct cooling can achieve optimal cooling effect; automatic water backup can rapidly lower temperature to set point.
- Advanced design of cycle can avoid high pressure explosion when system is under faults.

Accessory option

- Teflon hose is optional.
- RS485 communication function is optional.
- Display of mould temperature and mould return water temperature is optional.

■ Application

STM-WF series "Large Flow" water heaters are used to heat up the mould and maintain temperature, also they can be used in similar applications. High temperature water from the mould is returned to the cooling tank and cooled by direct cooling. It is then pressurized by the high-pressure pump, sent to the heating tank and finally to the mould with a constant temperature. The newly applied temperature controller can maintain an accuracy of $\pm 0.5^{\circ}\text{C}$.



Control Panel

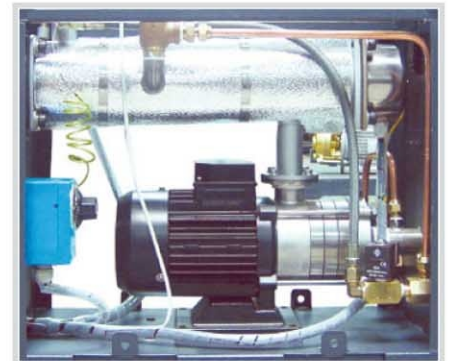

Inner Structure

STM-WF Series

Working Principle

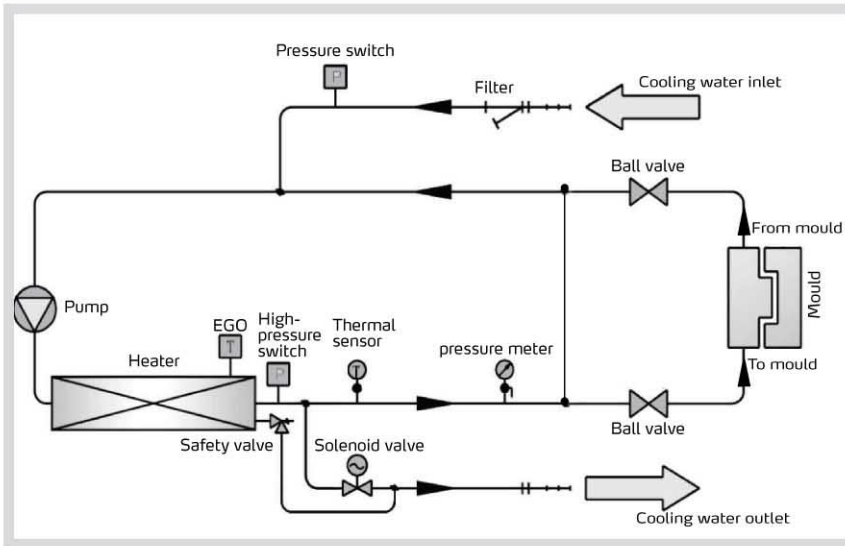

System flow (Direct Cooling)

High temperature water returns to the machine and then be pressured by pump to the heaters. After being heated, water will be forced to mould and continue the circle. In the process, if the temperature is too high, the system will activate the solenoid valve to let cooling water lower the temp. directly until the water is down to the system requirement. If the temp. keep increasing and reach to the set point of EGO, system will alarm and stop operation; when system pressure is too high (reach set value of high pressure switch), alarm would sounds and machine halts; if high pressure switch fails to function and system pressure continues to rise to reach set value of safety valve, safety valve would start up to release pressure; if cooling water pressure fails to reach setting, pressure switch would send a signal of water deficiency and system would launch low pressure alarm with machine halting.

Specifications

Model	Max. Temp.	Pipe Heater (kW)	Pump Power (kW, 50/60Hz)	Max. pump Flow (L/min) (50/60Hz)	Max. pump Pressure (bar, 50/60Hz)	Heating Tank Number	Main / Sub. Oil Tank (L)	Cooling Method	Mould Coupling* (inch)	Inlet/Outlet (inch)	Dimensions (mm) (H x W x D)	Weight (kg)
STM-607WF	120°C	6	0.55/0.55	58/67	2.8/2.6	1	3.0	Direct	1 (1x2)	1 / 1	635x320x640	60
STM-910WF		9	0.75/0.75	116/133	2.8/2.6	1	3.0		1 (1x2)	1 / 1	635x320x640	85
STM-1220WF		12	1.1/1.5	168/216	2.9/2.7	1	3.2		1 1/2 (1x2)	1 1/2 / 1 1/2	800x312x875	85
STM-2430WF※		24	2.2/2.2	333/333	3.2/2.9	2	7.2		1 1/2 (1x2)	1 1/2 / 1 1/2	855x435x840	156
STM-3650WF※		36	3.0/4.0	332/416	3.4 /4.3	3	12.0		1 1/2 (1x2)	1 1/2 / 1 1/2	955x465x1130	190
STM-4875WF※		48	5.5/5.5	533/500	4.5/3.8	4	16.0		1 1/2 (1x2)	1 1/2 / 1 1/2	980x480x1300	242

Notes: 1) "※" sands for vertical pump. "**" stands for options.

- In order to maintain stable temp. of heat transfer media, cooling water pressure should be no less than 2kgf/cm², but also no more than 5kgf/cm².
- Pump testing standard: Power of 50 / 60Hz, purified water in 20°C. (There is ± 10% tolerance for either max. flowrate or max. pressure).
- Power supply: 3Φ, 230/400/460/575VAC, 50/60Hz.

We reserve the right to change specifications without prior notice.

Pump Performance

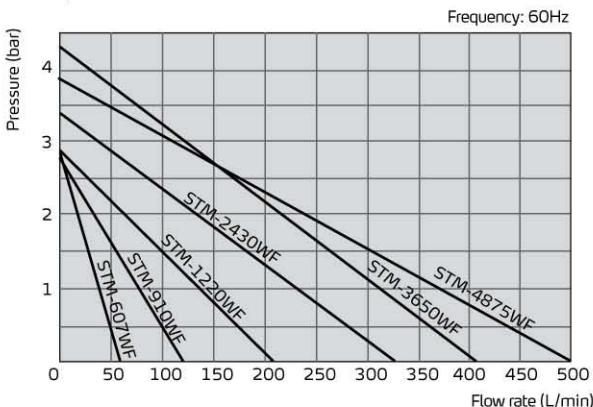

Reference formula of Mould Controllers model selection

$$\text{Heater Power (kW)} = \text{mould weight (kg)} \times \text{mould specific heat (kcal/kg}^\circ\text{C)} \times \text{temperature difference between mould and environment (}^\circ\text{C)} \times \text{safety coefficient} / \text{heating duration} / 860$$

Notes: safety coefficient range 1.3~1.5.

$$\text{Flow Rate (L/min)} = \text{heater power (kw)} \times 860 / [\text{heating medium specific (kcal/kg}^\circ\text{C)} \times \text{heating medium density (kg/L)} \times \text{in/outlet temperature difference (}^\circ\text{C)} \times \text{time (60)}]$$

Notes: Water specific heat = 1kcal/kg°C
 Heating medium oil specific heat = 0.49kcal/kg°C
 Water density = 1kg/L
 Heating medium oil density = 0.842kg/L

Shini Group

Addr.: No. 23, Minhe St., Shulin Dist.,
New Taipei, Taiwan

Tel: +886 2 2680 9119

Fax: +886 2 2680 9229

Email: shini@shini.com

Factories:

- Taiwan
- Dongguan
- Pinghu
- Ningbo
- Mumbai

2013-01-04-04 Copyrights Reserved.

www.shini.com