



# Five Axes Servo Driven Robot



ST5-700-1400D

## ■ Coding Principle

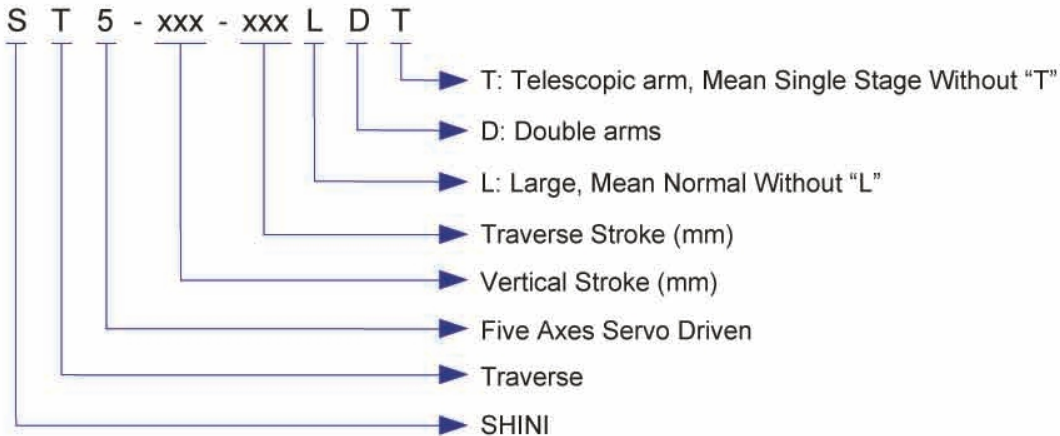

## ■ Features

- Appearance  
Designed with elegant appearance; Aluminium profiles are largely used to provide compact and streamlined appearance.
- Precision  
All linear movements are driven by heavy duty servo motors with cooperation of precise linear guide rails and high power V belts; Fast, silent, and precise. Wrist mechanism employs pneumatic driven rack and pinion system, which accomplishes smooth, stable and precise flipping motion. Vertical arms with telescopic design efficiently minimizes the cycle time and height of the robot.
- Safety  
Position limit sensors and blocks effectively prevent mechanical and electrical malfunctions. Control board is designed to CE EMC test with short circuit and noise proof functions.
- Convenience  
Control hardware fixtures are designed with flyer structure which provides benefit to maintenance. Cable drag chains help with cable management and ease for maintenance.
- Standardization  
All pneumatic accessories, electric accessories, and communication Protocols meet the global standards. Interface between injection molding machine and robot is designed to EUROMAP 12, EUROMAP 67 and SPI.
- Intelligence  
Base on VARAN BUS technology with world class 8.4 inch true color touch screen and object oriented program editor, complex and continuous projection can be easily programmed within minimum time. Closed circuit control system cooperating with plug and use hardware modules provides reliable movement that is capable of arranging, stacking, quality checking, in mold inserting etc. Real time remote monitoring and telediagnosis assist better equipment management. USB port allows fast data updating, saving and loading.



Control Panel

- User Friendly

Plug and use industrial connectors achieve simple installation and uninstallation. Servo driven axis provides the possibility of multi points for positioning products and sprues. Multi languages displays and spared communication connections with surrounds machines offer more flexibilities to global customers.

## ■ Application

The ST5 Series robot is designed for rapid and precise removal of sprue and products from injection molding machine, and place them at desired locations. Standard and telescopic arms are selectable to cooperate with 2-plate mold, 3-plate mold or hot runner system. Capable of arranging, stacking, quality checking and in mold placement. Suitable for injection molding machine under 3600T clamp force.

## ■ Outline Drawings

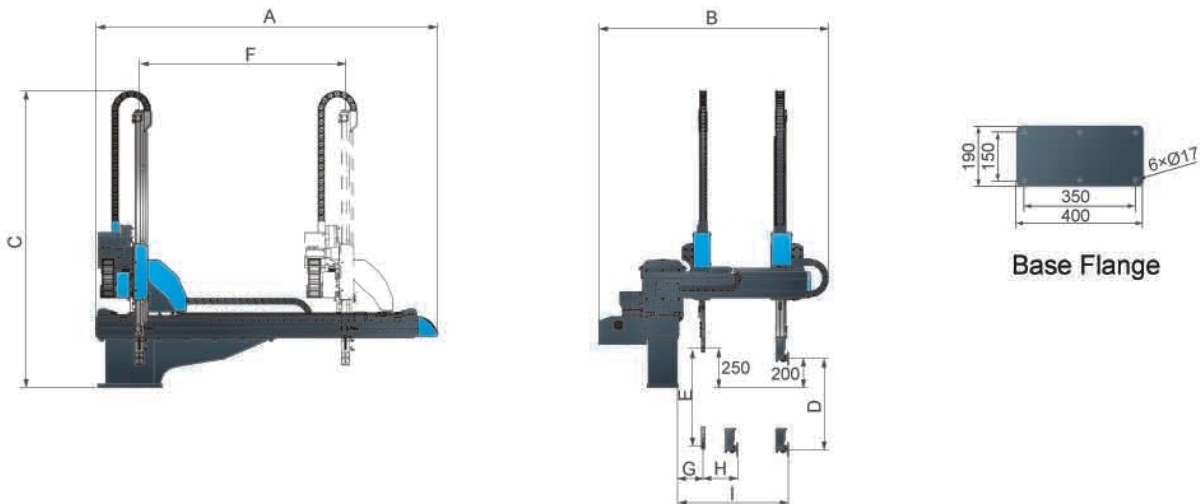

Five Axes Servo

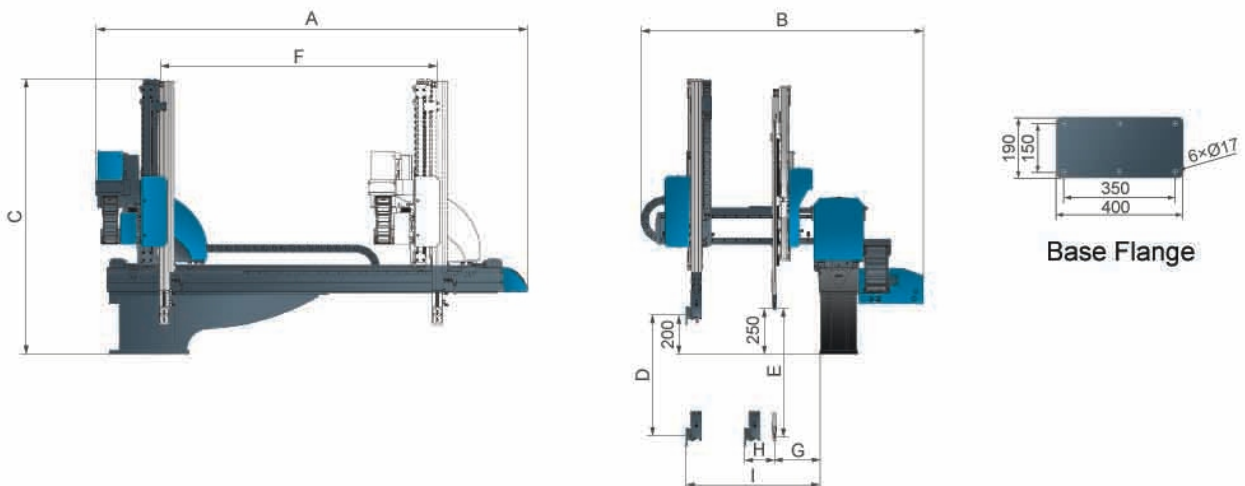

Five Axes Servo Telescopic

## Specifications

Model		ST5-550-1000D	ST5-700-1400D	ST5-900-1600D	ST5-1100-1800D
IMM (ton)		0 ~ 100	100 ~ 200	200 ~ 300	300 ~ 450
Traverse Stroke (mm)		1000	1400	1600	1800
Crosswise	Main arm	400	400	600	800
	Stroke (mm) Sub arm	400	400	600	800
Vertical	Main arm	550	700	900	1100
	Stroke (mm) Sub arm	600	750	950	1150
Max Load (with tool) (kg)		3	3	5	5
Min Pick-out Time (sec)		2.3	2.5	2.7	3
Min Cycle Time (sec)		7	7	8	8.5
Air Pressure (bar)		4 ~ 6	4 ~ 6	4 ~ 6	4 ~ 6
Max Air Consumption (NI/cycle) *		5	5	5	5
Weight (kg)		260	280	300	310
Dimensions (mm)	A	1750	2150	2350	2550
	B	1350	1350	1550	1750
	C	1700	1850	2050	2250
	D (max)	550	700	900	1100
	E (max)	600	750	950	1150
	F (max)	1000	1400	1600	1800
	G (min)	150	150	150	150
	H (min)	180	180	180	180
	I (max)	700	700	900	1100

- Note: 1. "M" stands for middle mold detector. ( Suitable for three-plate mold.) We reserve the right to change specifications without prior notice.  
 "EM12" stands for EUROMAP 12 communication interface.  
 "EM67" stands for EUROMAP 67 communication interface.  
 2. Power supply requirement: 1Φ, 200~240V, 50/60Hz.  
 3. "\*" Max air consumption for suction device 60NI/min.

Model (Telescopic)		ST5-700-1400DT	ST5-900-1600DT
IMM (ton)		100 ~ 200	200 ~ 300
Traverse Stroke (mm)		1400	1600
Crosswise	Main arm	300	500
	Stroke (mm) Sub arm	300	500
Vertical	Main arm	700	900
	Stroke (mm) Sub arm	750	950
Max Load (with tool) (kg)		3	5
Min Pick-out Time (sec)		2.1	2.3
Min Cycle Time (sec)		6	6.2
Air Pressure (bar)		4 ~ 6	4 ~ 6
Max Air Consumption (NI/cycle) *		5	5
Weight (kg)		260	280
Dimensions (mm)	A	2200	2400
	B	1450	1650
	C	1400	1600
	D (max)	700	900
	E (max)	750	950
	F (max)	1400	1500
	G (min)	225	225
	H (min)	160	160
	I (max)	680	880

- Note: 1. "M" stands for middle mold detector. ( Suitable for three-plate mold.) We reserve the right to change specifications without prior notice.  
 "EM12" stands for EUROMAP 12 communication interface.  
 "EM67" stands for EUROMAP 67 communication interface.  
 2. Power supply requirement: 1Φ, 200~240V, 50/60Hz.  
 3. "\*" Max air consumption for suction device 60NI/min.