



Hopper Dryers



SHD-300U



Refer carefully to the Manual before using products.



■ Coding Principle

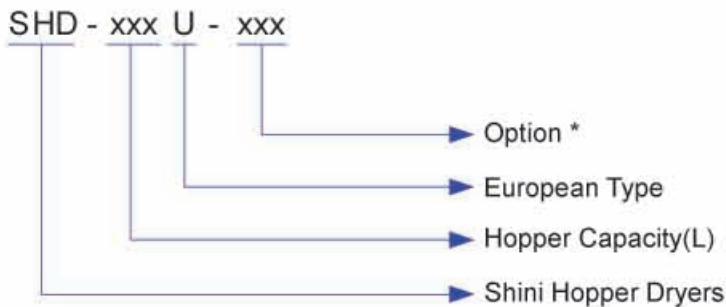

Note: *

P=For Polished Hopper Inside

HD=Heatless Dehumidifying

CE=CE Conformity

■ Features

Standard configuration

- Microprocessor is used for accurate temperature control.
- Digital P.I.D. temperature control with LED display.
- Overheat protection to ensure reliable operation.
- 7-day automatic start/stop timer to improve energy saving.
- Unique design of downblow air pipe can spread hot air evenly, keeping plastics dry and temperature stable to raise drying efficiency.
- Models SHD-80U and above have material clearance door to make the clean more convenient and effective.
- SHD-450U and models below are equipped with stainless steel lining aluminium base. SHD-600U~1200U are equipped with aluminium magnetic base. SHD-1500U and model above are equipped with manual butterfly valve.

Floor stand and safety protective ladder are standard equipments for SHD-1500U and models above.

Accessory option

- Cyclone dust separator, exhaust air filter, magnetic base and blower inlet filter are optional.
- Hot air recycler, suction box, hopper magnetic, N type floor stand and storage hopper are optional.
- Safety protective ladder is optional for SHD-1500U and models above.
- SHD-U-HD heatless dehumidifying hot-air dryer, fit with heatless regenerative device, which can supply dried air with relative low dew-point for speedup materials drying.
- SHD-U-HD heatless dehumidifying hot-air dryer, standard with hot air recyclers, which can save energy effectively. Without dust discharging, which ensures environment protection.



SHD-80U-HD & Floor Stand (Option) & Suction Box



SHD-1500U & Safety Protective Ladder (Option)



Shut-off Suction Box

Options

Material Suction Boxes

European tyle appearance design, work with dryer that has floor stand and vacuum loader, suitable for material suction and discharging.



Model	SHD-20U~120U	SHD-160U And Above
SBU	-20-38S	-160-38S
SBU	-20-50S	-160-50S
SBU	-20-38D	-160-38D
SBU	-20-50D	-160-50D

Note: 1) Install pneumatic shut off valve (add "V" at the back of model).
 2) Change into stainless steel (add "S" at the back of model).
 3) Suction box inside polished (add "P" at the back of model).
 4) Single tube suction box (add "S" at the back of model) , Double tube suction box (add "D" at the back of model).

Magnetic Bases



Including aluminum and stainless steel type, can work with dryers to effectively absorb the metal scraps to avoid material contamination.

Model	Applicable Model	Magnet Type	Aluminum Holder
MB-12	SHD-20U	MR-3	(88.5x78x2.3)x2
MB-20U			
MB-50	SHD-40U~120U		(88.5x78x2.3)x2
MB-40U			
MB-100			
MB-160U	SHD-160U~450U	(118.5x105x2.3)x2	

Note: "U" represents stainless steel base.

Hopper Magnets

Absorb metal scraps in the material to avoid the damage of molding screw.



Model	Applicable Model	Aluminum Holder
MR-5	SHD-20U	(148 x 80 x 2.3) x 2
MR-7	SHD-40U~80U	(190 x 80 x 2.3) x 2
MR-9	SHD-160U~600U	(240 x 80 x 2.3) x 2
MR-11	SHD-900U and above	(298 x 80 x 2.3) x 2

Floor Stands

Support dryer and hopper loader, easy for installation and transportation.



Floor Stand
(SHD-20U~750U Applicable)

Model	Applicable Model	Dimensions (mm)		
		Length	Width	Height
FSU-20	SHD-20U	550	450	790
FSU-40	SHD-40U	550	450	790
FSU-80	SHD-80U / 120U	722	552	840
FSU-160	SHD-160U / 230U	795	652	920
FSU-300	SHD-300U / 450U	930	790	970
FSU-600	SHD-600U / 750U	1200	1000	1130

Blower Inlet Filters

Effectively filters 80% dust-contained air from dryer to avoid air pollution.



Model	Filtering Barrel Dia. (mm)	Air Inlet Pipe Dia. (inch)	Air Outlet Pipe Dia. (inch)	Applicable Models	Fixed Plate	Blower Flange (With Air Quantity Adjustor)
AIF-20U	160	1.5	2	SHD-20U	SHD-20U	Air Inlet Flange for 0.12kW Blower
AIF-40U	160	1.5	2	SHD-40U	SHD-40U	Air Inlet Flange for 0.12kW Blower
AIF-80U	225	2	3	SHD-80U/120U	SHD-80U/120U	Air Inlet Flange for 0.12kW Blower
AIF-160U	225	2.5	3	SHD-160U/230U	SHD-160U/230U	Air Inlet Flange for 0.18kW Blower
AIF-300U	225	2.5	4	SHD-300U/450U	SHD-300U/450U	Air Inlet Flange for 0.25kW Blower
AIF-600U	225	3	4	SHD-600U/750U	SHD-600U/750U	Air Inlet Flange for 0.55kW Blower
AIF-900U	225	4	4	SHD-900U/1200U	SHD-900U/1200U	Air Inlet Flange for 0.55kW Blower
AIF-1500U	260	5	5	SHD-1500U/2000U	SHD-1500U/2000U	Air Inlet Flange for 3.00kW Blower
AIF-2500U	225	6	6	SHD-2500U/3500U	SHD-2500U/3500U	Air Inlet Flange for 5.50kW Blower
AIF-4000U	225	8	8	SHD-4000U/5000U	SHD-4000U/5000U	Air Inlet Flange for 7.50kW Blower
AIF-5500U	225	8	8	SHD-5500U/7000U	SHD-5500U/7000U	Air Inlet Flange for 12.0kW Blower
AIF-8000U	225	8	8	SHD-8000U	SHD-8000U	Air Inlet Flange for 22.0kW Blower

Hot Air Recyclers

Work with hopper dryer to make hot air form a semi closed circulated loop, it has features as follows:
 Hot air recycling and circulating to avoid indoor temp. rise up. Keep air in factory clean and ensure product quality;
 Save energy consumption up to 40% due to heat brought from hot air recycling; Economical and compact design make it suitable for all hopper dryers. Air supply is adjustable;



Model	Filtering Barrel Dia. (mm)	Air Inlet Pipe Dia. (inch)	Air Outlet Pipe Dia. (inch)	Applicable Models	Fixed Plate	Blower Flange (With Air Quantity Adjustor)
HAR-20U	160	1.5	2	SHD-20U	SHD-20U	Air Inlet Flange for 0.12kW Blower
HAR-40U	160	1.5	2	SHD-40U	SHD-40U	Air Inlet Flange for 0.12kW Blower
HAR-80U	225	2	3	SHD-80U/120U	SHD-80U/120U	Air Inlet Flange for 0.12kW Blower
HAR-160U	225	2.5	3	SHD-160U/230U	SHD-160U/230U	Air Inlet Flange for 0.18kW Blower
HAR-300U	225	2.5	4	SHD-300U/450U	SHD-300U/450U	Air Inlet Flange for 0.25kW Blower
HAR-600U	225	3	4	SHD-600U/750U	SHD-600U/750U	Air Inlet Flange for 0.55kW Blower
HAR-900U	225	4	4	SHD-900U/1200U	SHD-900U/1200U	Air Inlet Flange for 0.55kW Blower
HAR-1500U	260	5	5	SHD-1500U/2000U	SHD-1500U/2000U	Air Inlet Flange for 3.00kW Blower
HAR-2500U	225	6	6	SHD-2500U/3500U	SHD-2500U/3500U	Air Inlet Flange for 5.50kW Blower
HAR-4000U	225	8	8	SHD-4000U/5000U	SHD-4000U/5000U	Air Inlet Flange for 7.50kW Blower
HAR-5500U	225	8	8	SHD-5500U/7000U	SHD-5500U/7000U	Air Inlet Flange for 12.0kW Blower
HAR-8000U	225	8	8	SHD-8000U	SHD-8000U	Air Inlet Flange for 22.0kW Blower

Exhaust Air Filters

Effectively filters 90% dust-contained air from dryer to avoid air pollution.



Model	Filtering Barrel Dia. (mm)	Air Inlet Pipe Dia. (inch)	Air Outlet Pipe Dia. (inch)	Applicable Models	Fixed Plate
ADC-20U	159	1.5	2	SHD-20U	SHD-20U
ADC-40U	159	1.5	2	SHD-40U	SHD-40U
ADC-80U	225	2	3	SHD-80U/120U	SHD-80U/120U
ADC-160U	225	2.5	3	SHD-160U/230U	SHD-160U/230U
ADC-300U	225	2.5	4	SHD-300U/450U	SHD-300U/450U
ADC-600U	225	3	4	SHD-600U/750U	SHD-600U/750U
ADC-900U	225	4	4	SHD-900U/1200U	SHD-900U/1200U
ADC-1500U	260	5	5	SHD-1500U/2000U	SHD-1500U/2000U
ADC-2500U	225	6	6	SHD-2500U/3500U	SHD-2500U/3500U
ADC-4000U	225	8	8	SHD-4000U/5000U	SHD-4000U/5000U
ADC-5500U	225	8	8	SHD-5500U/7000U	SHD-5500U/7000U
ADC-8000U	225	8	8	SHD-8000U	SHD-8000U

SHD-U Series

Outline Drawings

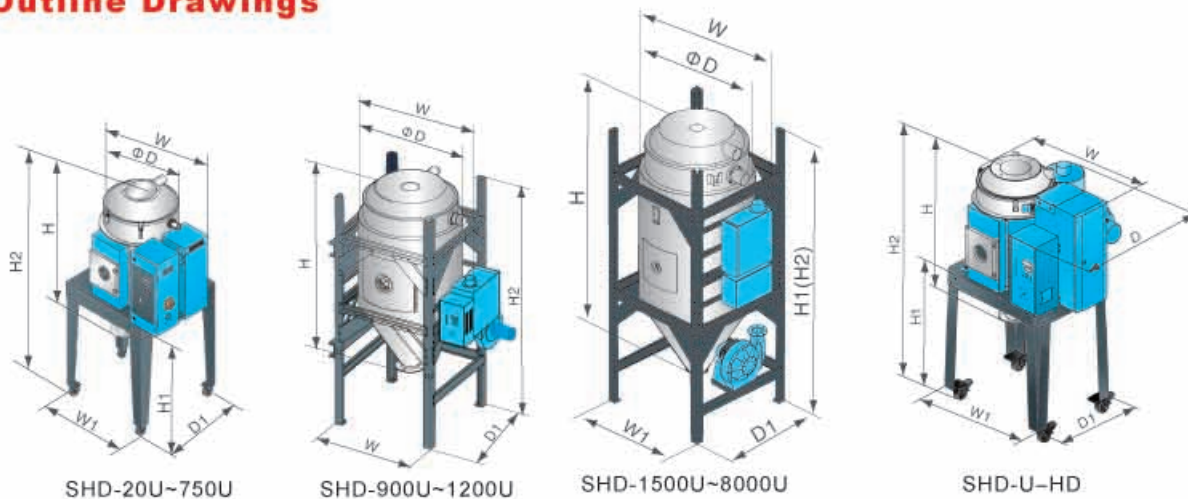

SHD-20U~750U

SHD-900U~1200U

SHD-1500U~8000U

SHD-U-HD

Specifications

Model	Heater Power (kW)	Blower (kW) (50/60Hz)	Hopper Capacity (L)	Dimensions (mm) H X W X D	Floor Stand (mm) H1 X W1 X D1	Whole Height (mm) H2	Air Inlet Pipe Dia. φA (inch)	Air Outlet Pipe Dia. φB (inch)	Weight (kg)
SHD-20U	2.2	0.05	20	730x575x325	790x450x550	1260	2	1.5	40
SHD-40U(-HD)	3	0.12	40	760x640x390	790x550x450	1295			
SHD-80U(-HD)	3.9	0.12	80	940x722x475	840x730x560	1465	2.5	2	50
SHD-120U(-HD)	3.9	0.12	120	1210x722x475	840x730x560	1735			
SHD-160U	6	0.12	160	1225x822x575	920x652x795	1825	3	2.5	90
SHD-230U	6	0.12	230	1505x822x575	920x652x795	2105			
SHD-300U	12	0.18	300	1450x945x695	970x790x930	2085	4	3	130
SHD-450U	12	0.18	450	1850x945x695	970x790x930	2435			
SHD-600U	18	0.55	600	1820x1170x915	1130x1000x1200	2470	4	3	200
SHD-750U	18	0.55	750	2100x1170x915	1130x1000x1200	2780			
SHD-900U	18	0.55	900	2070x1410x1050	2760x1130x1130	2760	4	4	410
SHD-1200U	18	0.55	1200	3350x1410x1050	3190x1145x1145	3190			
SHD-1500U	32	3	1500	2950x1640x1250	3470x1340x1340	3470	5	5	685
SHD-2000U	32	3	2000	3350x1542x1250	3870x1340x1340	3870			
SHD-2500U	58	5.5	2500	3510x1798x1400	4000x1482x1482	4000	6	6	800
SHD-3000U	58	5.5	3000	3910x1798x1400	4400x1482x1482	4400			
SHD-3500U	64	7.5	3500	4310x1798x1400	4800x1482x1482	4800	7.5	7.5	1010
SHD-4000U	64	7.5	4000	4050x2010x1600	4550x1680x1680	4550			
SHD-4500U	80	11	4500	4350x2010x1600	4850x1680x1680	4850	8	8	1260
SHD-5000U	80	11	5000	4650x2010x1600	5150x1680x1680	5150			
SHD-5500U	96	15	5500	4950x2010x1600	5450x1680x1680	5450	8	8	1480
SHD-6000U	96	15	6000	4350x2250x1800	4870x1930x1930	4870			
SHD-6500U	112	18.5	6500	4600x2250x1800	5120x1930x1930	5120	10	10	1625
SHD-7000U	112	18.5	7000	4850x2250x1800	5370x1930x1930	5370			
SHD-8000U	128	22	8000	5350x2250x1800	5620x1930x1930	5620	10	10	1820

- Note: 1) For polished hopper inside, add "P" at model behind.
 2) Blower is included in machine net weight, but floor stand is not included.
 3) Upon request, it can be built to comply with worldwide electrical safety standards (For example : CE, UL, CSA, JIS etc.).
 4) Power: 3Φ, 230/400/460/575VAC, 50/60Hz.

We reserve the right to change specifications without prior notice.



SHINI PLASTICS TECHNOLOGIES, INC.

Headquarters:

Shini Plastics Technologies, Inc.

No.23, Minhe St., Shulin Dist.,
Xinbei City, Taiwan

tel: +886 2 2680 9119

fax: +886 2 2680 9229

email: shini@shini.com

Factories:

- Taiwan
- Dongguan
- Ningbo
- Pinghu
- Mumbai